

Installation, Operation & Maintenance

DOROT Quick Pressure Relief Valve (QR)

Control Function QR, Quick Pressure Relief Valve

Applicable models: S80

Sizes: 1½" – 4" R / 40 - 100mmR

1. Function Description

DOROT S80, QR 2W 29-500, is an automatic, 2-way, pilot-controlled quick pressure relief valve. The valve maintains a closed position if system pressure is lower than the preset pressure, and instantly opens once pressure reaches the preset value. The valve closes at a slow, adjustable pace to prevent secondary surges.

2. Technical Features

- Medium: Water; natural, non-aggressive fluids, other (contact Aquestia)
- Pressure rating: 10 bar (145 psi)
- Temp. range: 2 – 60°C (35 – 140°F)
- Flow speed for continuous operation: 0.1 – 5.5 m/sec (0.3 – 18 ft/sec)
Maximal flow speed for intermittent operation: 8 m/sec (26 ft/sec)

Notes:

- If the designed/actual operating conditions on-site are incompatible with the definitions above, please contact Aquestia application engineering.

Refer to the specific valve model publications for further details.

3. Safety Guidelines

Before using this product:

- Read and understand the instructions and save them for future reference.

Before disassembly of any accessory or component:

- All internal pressures must be relieved, and all media drained from the system in accordance with all applicable procedures.
- Pressure must be 0 (zero) bar/psi.

Please note:

- Damage to the system/surroundings may occur if installation, commissioning, operation, or maintenance instructions are not followed, or if applicable codes of practice and regulations are ignored.
- Electrical works, (e.g., connection of solenoid valves, limit switches etc.), must be performed by a certified electrician.
- Errors in the layout design, installation or operation may affect the valve performance and pose a risk to the system and/or the operator/users.
- The system layout, installation, and commissioning are the responsibility of the system designer, installer and/or user.
- In any case of doubt and prior to taking any further action, please contact an Aquestia representative for assistance.

ⓘ Failure to follow the instructions set forth in this publication could result in property damage, personal injury, or death from hazards that may be associated with this type of equipment.

Installation, Operation & Maintenance

4. Pre-installation

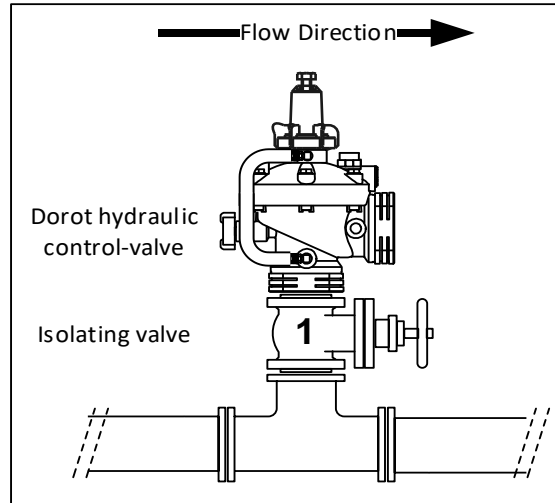

- The valve can be installed in any position, although installation with the bonnet facing up is recommended for ease of maintenance.
- Flow direction must match the engraved arrow on the bonnet.
- It is highly recommended to install an upstream manual isolation valve [1], as shown in the diagram above.
- Flush the pipeline, upstream of the valve before assembly of the control valve.
- DOROT valves are generally designed for use in freshwater systems. Please consult Aquestia application engineering if other media is to be used.

Installation, Operation & Maintenance

5. Control Trim Design

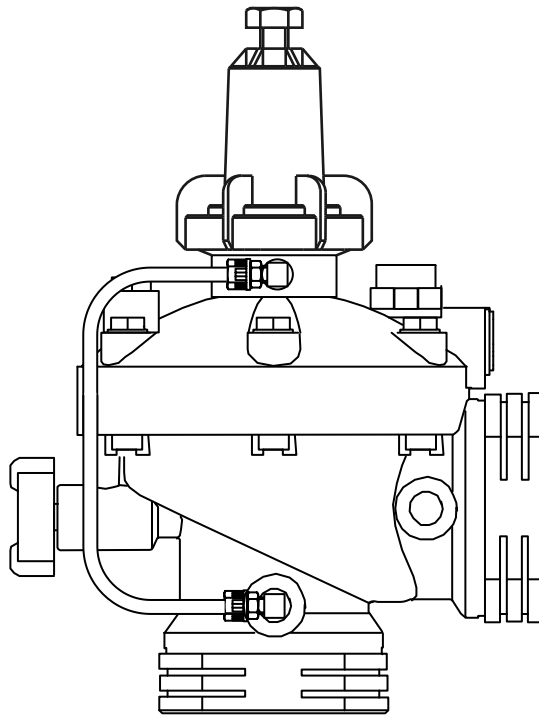

6. Commissioning & Adjustment

- a. Turn pilot valve adjustment bolt, clockwise completely.
- b. Start the pump or open upstream isolation valve [1] (see section 4).
- c. Slowly turn pilot valve adjustment bolt counterclockwise, until pilot vent starts to drip. After dripping begins, turn pilot valve adjustment bolt clockwise 1 turn.

ⓘ Pressurizing the downstream system must be done slowly to prevent pressure surges.

Installation, Operation & Maintenance

7. Troubleshooting			
Issue	Cause	Check	Solution
Valve fails to open	Pilot incorrectly adjusted.	Verify upstream pressure.	Readjust pilot set point, (7-10 mwc above normal maximal pressure).
Valve fails to close or leaks	Pilot incorrectly adjusted.	Verify upstream pressure.	Readjust pilot set point (7-10 mwc above normal maximal pressure).
	Debris between diaphragm and diaphragm seat.	Reduced water flow, noisy.	Dismantle, clean, and reassemble.
	Damaged diaphragm.	Continuous flow at discharge.	Replace diaphragm.

Aquestia Ltd. reserves the right to make product changes without prior notice.

To ensure receiving updated information on parts specifications, please contact us at info@aquestia.com.

Aquestia Ltd. shall not be held liable for any errors. All rights reserved.