

# DOROT S80 series



Advanced hydraulic solutions for optimal management  
of liquid conveyance systems

 **Aquestia**

Directing the Flow

## Globe and Angle Valves

Hydraulic valve for agricultural, irrigation, greenhouses, filtration systems and public turf irrigation

## Features and Benefits

- Simple, reliable and economical
- Angle or straight, globe- pattern valve, activated by a fully-supported diaphragm
- Durable, corrosion free materials
- Unique clog-free labyrinth inlet of the activation water on electric 2-way valves
- 3 Position Manual override on electric 2-way valves
- Operation at wide range of flow rates, from near zero to the maximal flow
- Electric 2-way or hydraulic / electric 3-way actuation
- All of the control system's devices are assembled on the valve's bonnet. No tubes are connected to the body
- Removable flow control stem handle (optional)
- Integral stainless-steel filter

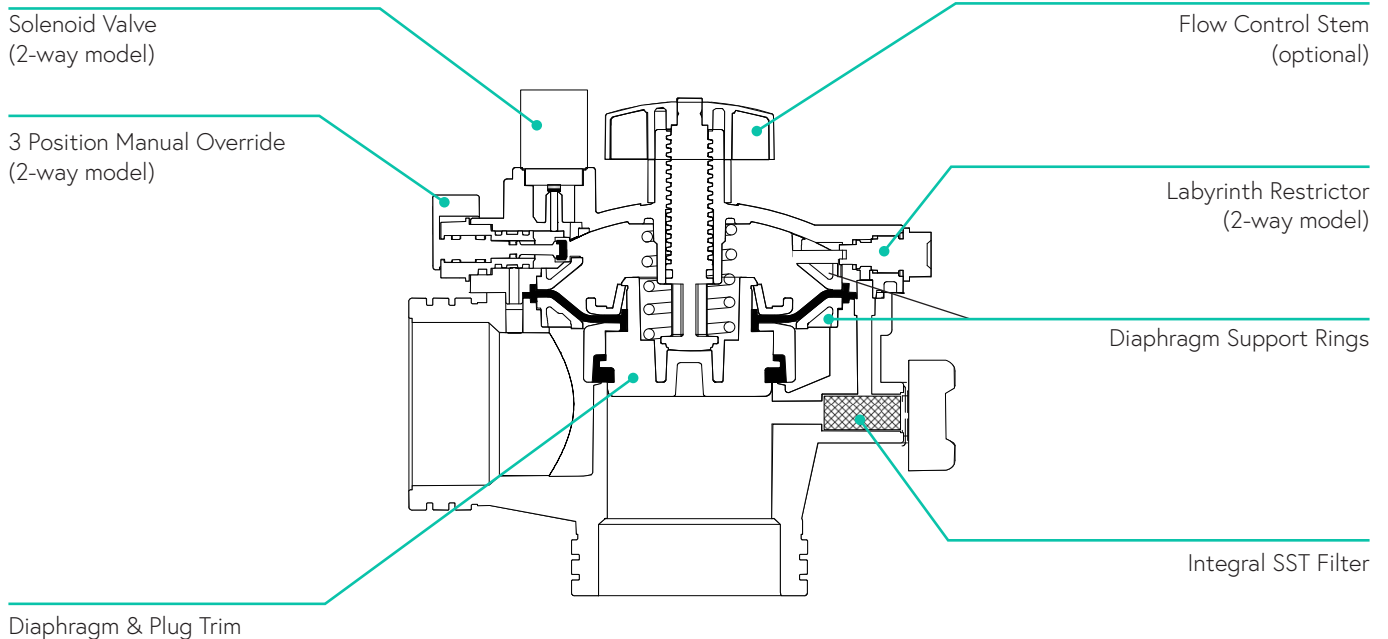
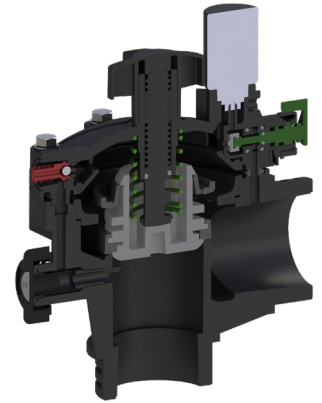

## Technical Data

### Head Losses

Flow		Head loss (3-way valves)							
		40mm, 1½"				50mm, 2"			
		Angle		Straight		Angle		Straight	
gpm	m3/h	psi	bar	psi	bar	psi	bar	psi	bar
22	5	0.19	0.01	0.33	0.02	0.11	0.01	0.19	0.01
44	10	0.75	0.05	1.33	0.09	0.43	0.03	0.75	0.05
88	20	3	0.21	5.33	0.37	1.72	0.12	3	0.21
132	30	6.74	0.46	12	0.83	3.9	0.27	6.74	0.46
176	40					6.9	0.48	12	0.83

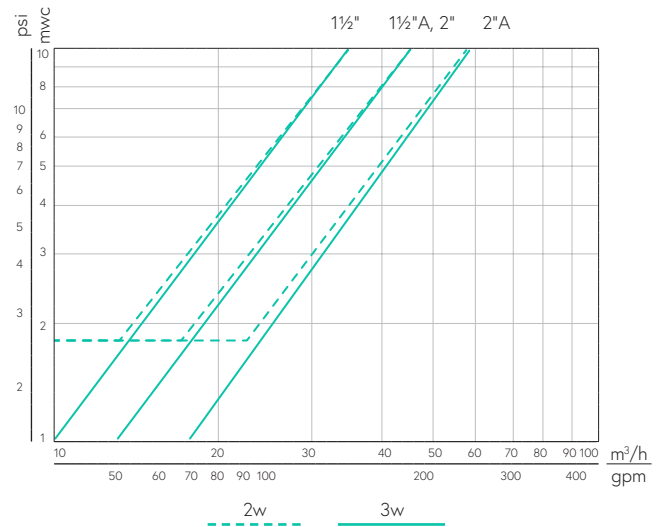

### Dimensions

		40mm, 1½"		50mm, 2"	
		Angle	Straight	Angle	Straight
Height	mm	171	159	171	166
	inch	6.73	6.23	6.73	6.54
Width	mm	163	163	163	163
	inch	6.42	6.42	6.42	6.42
Length - Straight Center to outlet	mm	88	165	88	165
	inch	3.46	6.5	3.46	6.5

### Operation Data

		40mm, 1½"	50mm, 2"
Max. Flow	m³/hr	25	40
	gpm	110	176
Pressure range	bar	0.5 - 10	
	psi	7 - 145	
Max. Water temp.	C°	60	
	F°	140	
Max. Ambient temp.	C°	52	
	F°	125	

### Electrical Specifications

- Standard: 24 VAC 50/60 Hz. ±10%  
Optional: other voltage rating or latching DC operators
- Current: 0.26 Amp Inrush; 0.12 Amp holding

# DOROT S80 3/4"-1"



## Turf Valves

Electric valve for gardens, parks and golf courses

## Features and Benefits

- Simple, reliable and economical
- Globe- pattern valve, activated by a fully- supported diaphragm
- Durable, corrosion free materials
- Operation at wide range of flow rates, from near zero to the maximal flow
- Internal bleed manual override opening
- Removable flow control stem handle (optional)
- No filters

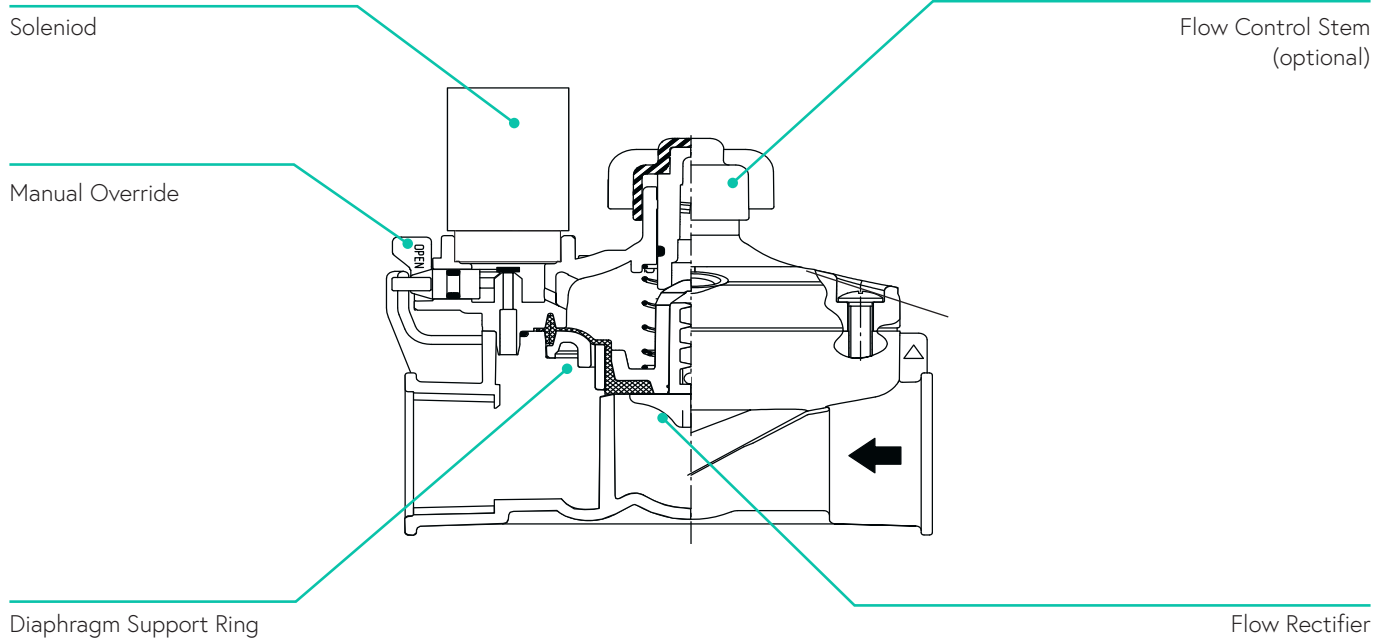

## Technical Data

### Head Losses

flow		Head loss			
		20mm, $\frac{3}{4}$ "		25mm, 1"	
gpm	m <sup>3</sup> /h	psi	bar	psi	bar
2.2	0.5	1.42	0.10	1.42	0.10
4.4	1	1.60	0.11	1.42	0.10
8.8	2	1.65	0.11	1.42	0.10
13.2	3	2.90	0.20	1.65	0.11
17.6	4	4.35	0.30	2.61	0.18
22.0	5	6.82	0.47	3.63	0.25
26.4	6			4.83	0.33
30.8	7			6.09	0.42

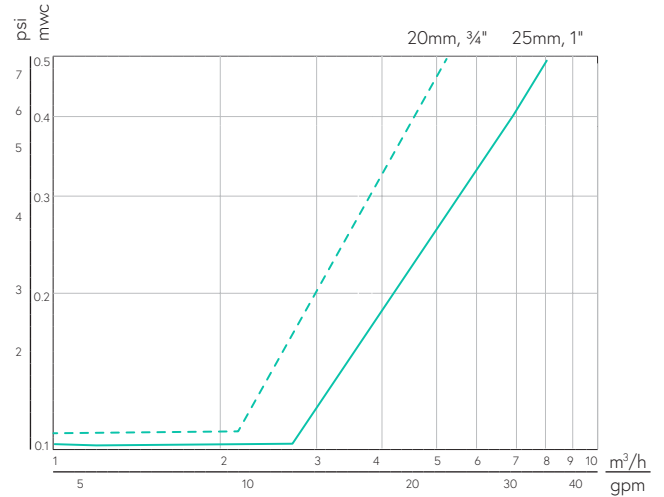

### Dimensions

		20mm, $\frac{3}{4}$ "	25mm, 1"
Height	mm	109	112
	inch	4.3	4.4
Width	mm	75	75
	inch	3	3
Length - Straight Center to outlet-Angle	mm	98	103
	inch	3.9	4.1
Weight	kg	0.28	0.29
	lbs	0.62	0.64

### Operation Data

		20mm, $\frac{3}{4}$ "	25mm, 1"
Max. Flow	m <sup>3</sup> /hr	6	10
	gpm	26	44
Pressure range	bar	0.5 - 10	
	psi	7 - 145	
Max. Water temp.	C°	60	
	F°	140	
Max. Ambient temp.	C°	52	
	F°	125	

### Electrical Specifications

- Standard: 24 VAC 50/60 Hz.  $\pm 10\%$   
Optional: other voltage rating or latching DC operators
- Current: 0.26 Amp Inrush; 0.12 Amp holding

## "T" Valve

Dorot presents the S80 V, a specially designed plastic valve for agricultural applications, combining high quality, affordability, ease of installation and a durable construction.



## Features and Benefits

- Specially designed for Irrigation when one inlet and two outlets are required
- The 80-V valve includes a unique replaceable connector, which in case of wear and tear, doesn't require to replace the entire valve
- A uniquely designed diaphragm allows steady regulation even at low flow conditions
- High-capacity design with extremely low head losses
- Low required operation pressure
- Light weight
- Corrosion resistant high quality materials
- Simple and reliable
- Wide range of control applications

## Principle of Operation

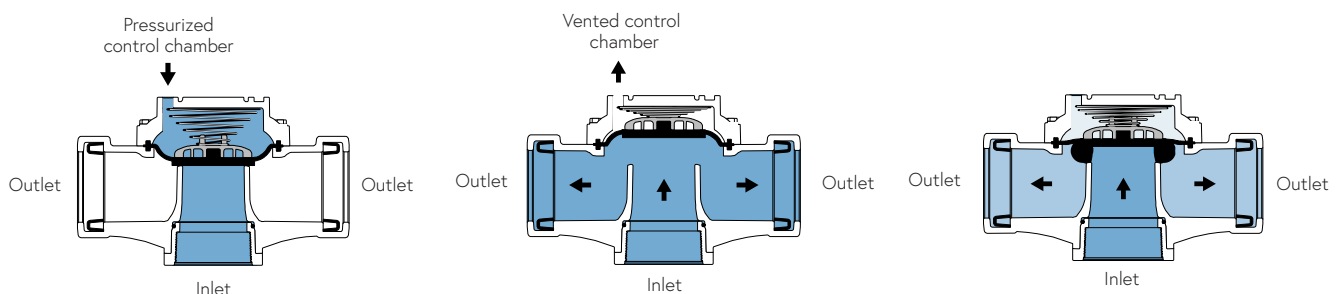

### Closed mode

When inlet pressure is applied to the control chamber the valve closes drip-tight.

### Open mode

When the operating pressure is relieved from the control chamber, the line pressure at the valve inlet opens the valve.

### Modulating mode

The position of the diaphragm is dictated by the volume of water in the control chamber, which is regulated by the pilot valve in order to maintain a preset pressure value.

## Technical Data

### Head Losses

Flow rate	Headloss			
	Two outlets		Single outlet	
m <sup>3</sup> /h	bar	psi	bar	psi
25	0.02	0.3	0.05	0.7
50	0.08	1.16	0.19	2.75
75	0.17	2.46	0.43	6.2
100	0.31	4.5	0.76	11

For calculating the loss through the fully open valve, use the following equation:

$$\Delta P = \left( \frac{Q}{K_v} \right)^2$$

Q in m<sup>3</sup>/h

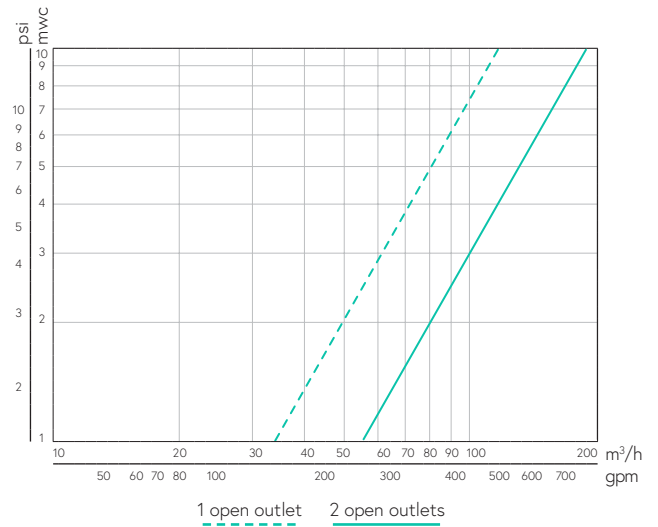

### Dimensions

Dimensions	Metric	US
D1 (mm / inch)	75	3
D2 (mm / inch)	75	3
H1 – Height (mm / inch)	193	8
H2 (mm / inch)	76	3
L (mm / inch)	310	12
Weight (kg / lb)	1.6	3.5

### Operation Data

Operating pressure range	bar	0.2 - 10
	psi	3 - 145
Max. recommended flow	m <sup>3</sup> /h	100
	gpm	440
Minimal flow	m <sup>3</sup> /h	<1
	gpm	<5
Kv / Cv – two open outlets	m <sup>3</sup> /h @ 1bar	180
	gpm @ 1psi	792
Kv / Cv – one open outlet	m <sup>3</sup> /h @ 1bar	115
	gpm @ 1psi	506

### Parts & Materials

Part	Description	Material
1	Body	GRP
2	Bonnet	GRP
3	Spring	SST 302
4	Spring Seat	GRP
5	Diaphragm	NR
6	Bolts & Nuts	SST 304
7	Seal	NBR
8	O-ring	NBR
9	Replaceable connection	Reinforced-Plastic / Brass

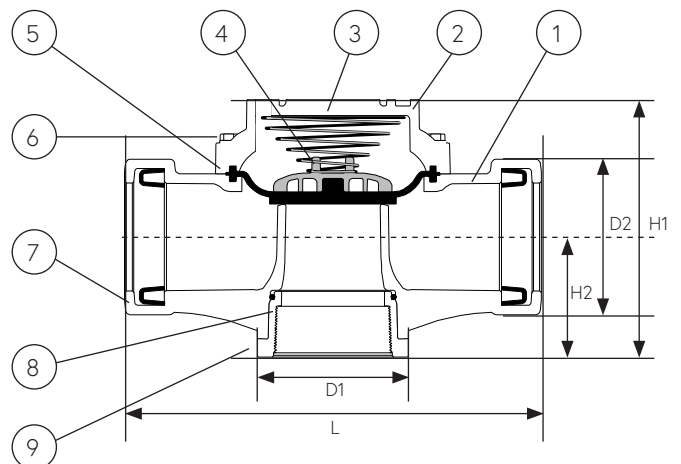

## Angle Valve

Dorot presents the S80 A, a specially designed valve for agricultural applications, combining high quality, affordability, ease of installation and a durable construction.



## Features and Benefits

- Angle-pattern valve, activated by a fully-supported diaphragm
- Threaded or Flanged connection
- Durable, corrosion free materials
- A uniquely designed diaphragm allows steady regulation even at low flow conditions
- High-capacity design with extremely low head losses
- Simple and reliable
- Wide range of control applications

## Principle of Operation

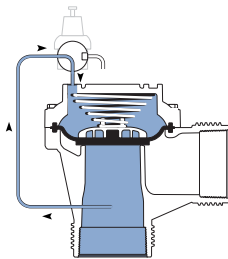

### Closed mode

When inlet pressure is applied to the control chamber the valve closes drip-tight.

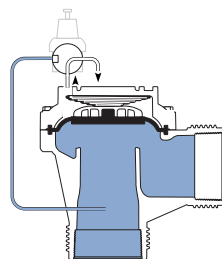

### Open mode

When the operating pressure is relieved from the control chamber, the line pressure at the valve inlet opens the valve.

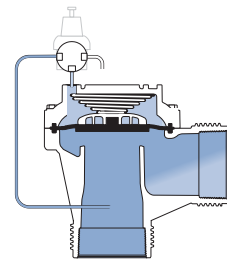

### Modulating mode

The position of the diaphragm is dictated by the volume of water in the control chamber, which is regulated by the pilot system in order to maintain a preset pressure value.

## Operation Data

Performance	Metric	US
Pressure range (bar / psi)	1 - 10	15 - 150
Max. recommended flow (m <sup>3</sup> /h / gpm)	100	440
Minimal flow (m <sup>3</sup> /h / gpm)	<1	<5
Kv / Cv (m <sup>3</sup> /h @ 1bar / gpm @ 1psi)	150	175

Max. Fluid Temperature: 70°C/ 160°F

## Technical Data

### Head Losses

Flow rate	Headloss	
	m <sup>3</sup> /h	bar
25	0.02	0.3
50	0.1	1.45
75	0.25	3.6
100	0.45	6.5

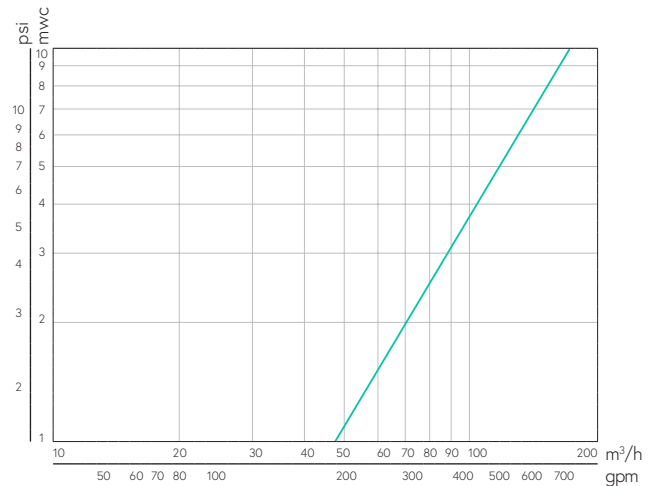

## Dimensions

Dimensions	Metric	US
W (mm / inch)	195	75/8
H1 - Height (mm / inch)	45	111/16
L1 (mm / inch)	160	65/16
L2 (mm / inch)	130	51/8
Df 3"/80mm	194	75/8
Df 4"/100mm	230	9
Weight without flanges (kg / lb)	2.5	5.5
Weight with 3" flanges (kg / lb)	3.8	8.3
Weight with 4" flanges (kg / lb)	4.2	9.2

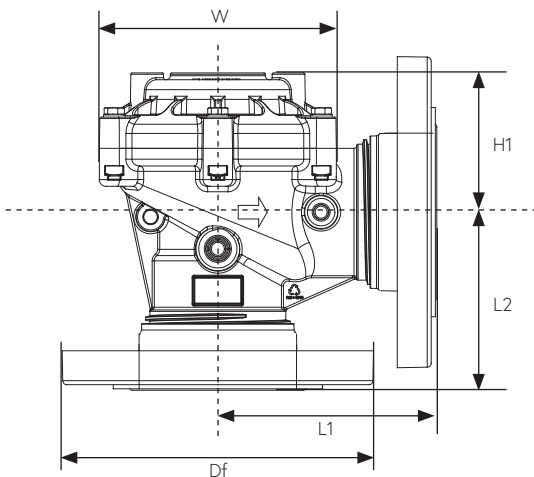

## Parts & Materials

Part	Description	Material
1	Body	GRP
2	Bonnet	GRP
3	Spring	SST 302
4	Bolts & Nuts	SST 304
5	Diaphragm	NR
6	Spring Seat	GRP
7	Flange	Plastic
8	Flange adapter	PA-GF
9	O-ring No. 2-347	NBR
10	O-ring No. 2-342	NBR

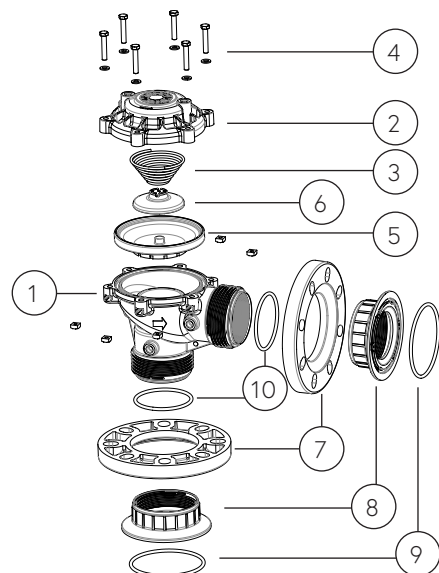

## Quick Pressure Relief Valve

The S80 A QR is a pilot-operated, quick-acting pressure relief valve, designed for the protection of pumps, filtration systems and pipelines in mining (corrosive fluid), and agricultural/irrigation applications. The valve continuously senses pressure in the system, keeping it in a drip-tight, closed position as long as pressure is low. The valve instantly opens in cases where system pressure reaches a preset, critical value, that allows surplus flow out from the system. Closing speed is regulated to enable smooth, quiet attenuation of pressure surges.



## Features and Benefits

- Dependable, moderately-priced, pilot-operated valve
- Eliminates most of the drawbacks of spring-loaded relief valves
- Fast opening and slow, regulated closure - prevents shuttering and secondary surges
- The relief-flow can be directed away or can be connected to a collector
- Extremely accurate: will open and close at the same pressure setting
- Leak-proof design
- Constructed from rugged, corrosion-proof composite materials
- May be ordered factory set and sealed under actual hydrostatic conditions, or can be shipped to you for final field adjustment
- Small, light-weight and easy to adjust with just a small key and applying small torque
- Provides relief setting-range from 1 to 9 bar / 15-130 psi

## Principle of Operation

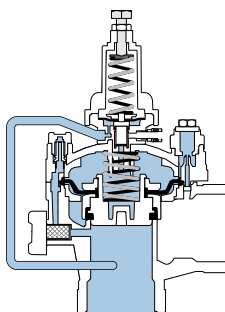

### Normal System Pressure

The valve maintains a closed position as long as the system pressure is lower than the pre-set value

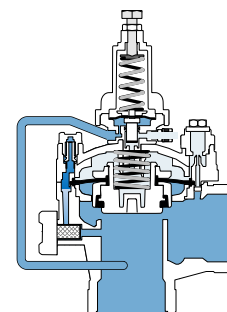

### High Pressure

The valve instantly opens once the pressure reaches the pre-set value. The valve then re-closes at a slow, adjustable rate.

## Technical Data

### Head Losses (m<sup>3</sup>/h)

	ΔP (bar)									
	0	1	2	3	4	5	6	7	8	9
1½"	0	37	52	64	74	82	90	97	104	110
2"	0	46	66	80	93	104	114	123	131	139
3"	0	120	170	208	240	268	294	317	339	360

### Spring Adjustment Range

Spring number	Color	bar	psi
65	Red	1-10	15-150

## Dimensions

Dimension		35mm, 1½"	50mm, 2"	80mm, 3"
L1	mm / inch	88 / 3½	88 / 3½	160 / 6 <sup>3</sup> / <sub>16</sub>
L2	mm / inch	70 / 2 <sup>11</sup> / <sub>16</sub>	70 / 2 <sup>11</sup> / <sub>16</sub>	129 / 5
H1	mm / inch	180 / 7	180 / 7	220 / 8½
Df	mm / inch	163 / 6½	163 / 6½	-
Df 3"	mm / inch	-	-	194 / 7¾
Df 4"	mm / inch	-	-	230 / 9
Weight	kg / lbs	1.1 / 2.4	1.1 / 2.4	4 / 8.82

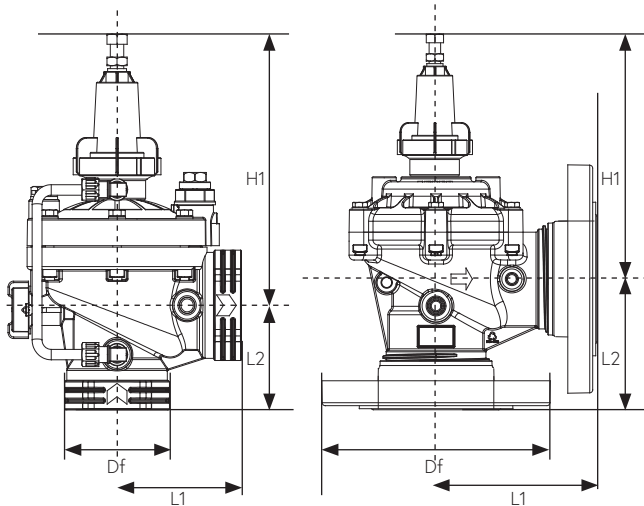

## Hydraulic Data

Performance		Metric	US
Max. Flow	1½"	65 m <sup>3</sup> /h	285 gpm
	2"	100 m <sup>3</sup> /h	465 gpm
	3"	200 m <sup>3</sup> /h	880 gpm
Min. Pressure		1 bar	14.5 psi
Max. Pressure		10 bar	145 psi
Max. Temperature		60°C	140°F
Kv / Cv	1½"	46	54
	2"	58	68
	3"	150	175

## Parts & Materials

Part	Description	Material
1	Body	GRP
2	Diaphragm assembly	GRP+NR
3	Main Spring	SST
4	Pilot-valve bonnet	GRP
5	Control tube	PP

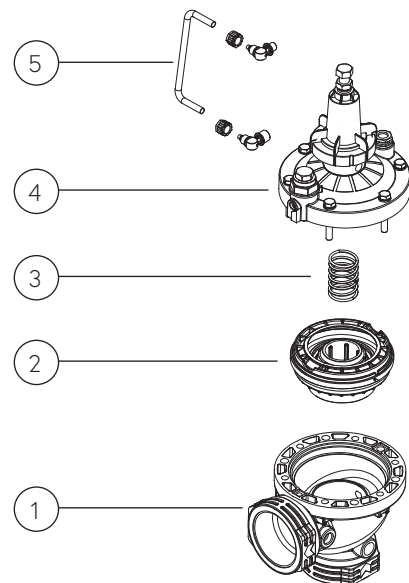

## Ordering Guide

Ordering data	Ordering code					Ordering data
	<b>80A</b>	□	<b>QR</b>	□□□	□□	
Diameter						<b>Additional Features</b>
1 1/2" / 40 mm *	→	1.5			-	← None
2" / 50 mm *	→	2			HP	← High Pressure
3" / 80 mm	→	3				<b>End Connections</b>
4"R	→	4		BSP	←	BSP
				NPT	←	NPT
				UNF	←	Universal Flanged**

\* For 1 1/2" and 2" valve only- can be supplied in horizontal configuration

\*\* For 3" and 4"R only

### Example:

<b>80A</b>	2	<b>QR</b>	BSP
------------	---	-----------	-----

### **BSP 80A-2-QR-BSP**

Quick Pressure Relief Valve 2"

## Double Outlet Valve

Dorot presents the S80 W valve, designed especially for agricultural-irrigation applications, featuring high quality, affordability, ease of installation and a durable construction.



## Features and Benefits

- For irrigation schemes where one inlet and two independent outlets are required
- Features a unique replaceable inlet connector - if worn-out, swap it with a new inlet instead of having to invest in a new complete valve
- A unique diaphragm design allows steady regulation even at low flow rates
- Designed for high flow rates while maintaining extremely low head losses
- Wide operation pressure range, from as low as 0.5 bar up to 10 bar
- Uses light-weight, high quality, corrosion resistant materials
- Simple and reliable
- Allows for a wide range of control applications

## Principle of Operation

### Opened Valve

When the control-chamber is de-pressurized, the inline pressure is forcing the diaphragm to an open position

### Closed Valve

When the upstream pressure is applied into the control-chamber, it forces the diaphragm down to the closed position

### Modulating Valve

The diaphragm position is set by the volume of water in the control chamber, which is controlled by a pilot system (not shown)

### Open Valve

Vented control chamber

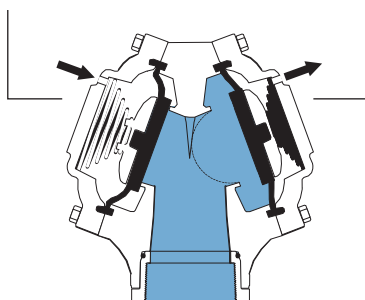

### Closed Valve

Pressurized control chamber

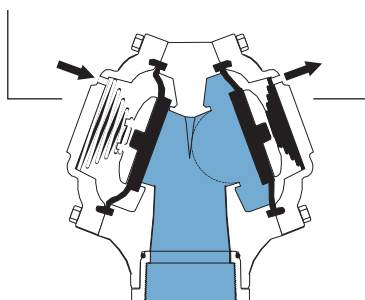

### Modulating Valve

Partially pressurized control chamber

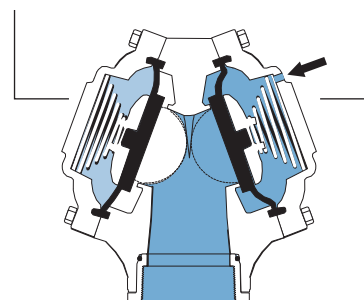

### Closed Valve

Pressurized control chamber

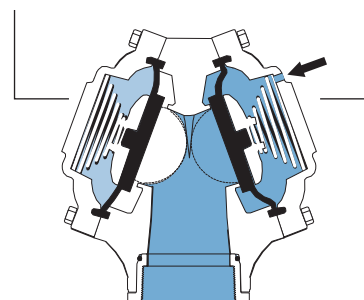

## Technical Data

### Head Losses

Flow rate		Head loss			
		Two outlets		Single outlet	
m <sup>3</sup> /h	gpm	bar	psi	bar	psi
25	110	0.01	0.2	0.06	1
50	220	0.06	1	0.23	3.5
75	330	0.13	2	0.51	7.5
100	440	0.23	3.5	0.91	13.5

For calculating the loss through the fully open valve, use the following equation:

$$\Delta P(\text{bar}) = \left( \frac{Q[\frac{\text{m}^3}{\text{hr}}]}{K_v} \right)^2 \quad \left| \quad \Delta P(\text{psi}) = \left( \frac{Q[\text{gpm}]}{C_v} \right)^2$$

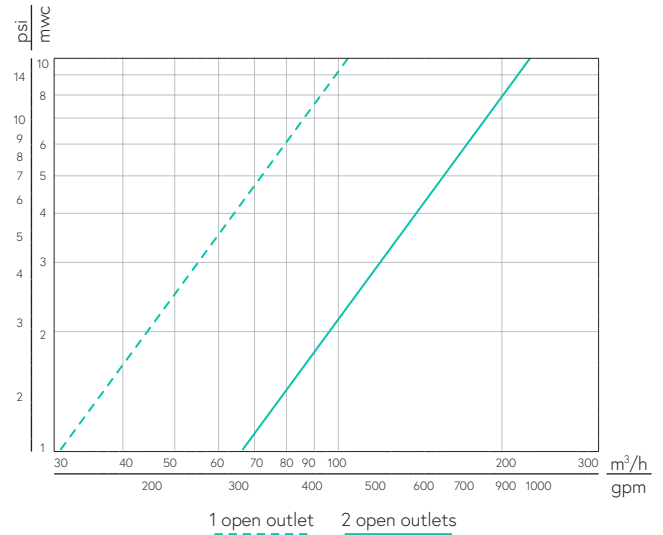

### Dimensions

Dimension	Metric	US
D1 (mm/inch)	111.5	4 <sup>3</sup> / <sub>8</sub>
D2 (mm/inch)	104	4
H1 -Height (mm/inch)	259	10 <sup>3</sup> / <sub>16</sub>
H2 (mm/inch)	139	5 <sup>1</sup> / <sub>2</sub>
L1 (mm/inch)	194	7 <sup>6</sup> / <sub>16</sub>
L2 (mm/inch)	202	7 <sup>9</sup> / <sub>2</sub>
Weight (kg/lb) *	4.4	9.7

\* Without flanges

### Operation Data

Operating pressure range	bar	0.5 - 10
	psi	7 - 145
Max recommended flow (single outlet)	m <sup>3</sup> /h	100
	gpm	440
Minimal flow	m <sup>3</sup> /h	<1
	gpm	<5
Kv / Cv two open outlets	m <sup>3</sup> /h @ 1 bar	210
	gpm @ 1 psi	242
Kv / Cv one open outlet	m <sup>3</sup> /h @ 1 bar	105
	gpm @ 1 psi	121

### End Connections

Inlet: 3" / 80mm BSP/NPT Female-threaded Metric	
Outlets:	BSP/NPT Female-threaded
	3" and 4" Universal flanged
	3" Grooved (Optional)

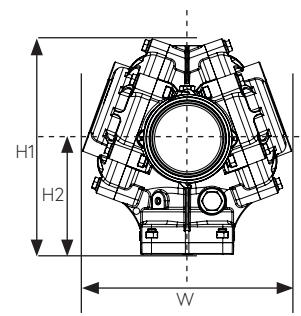
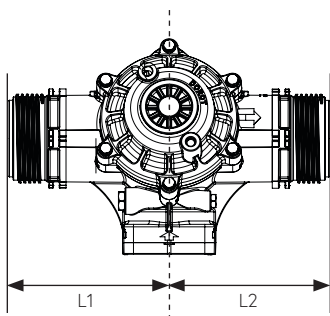



Directing the Flow

## Advanced hydraulic solutions for optimal management of liquid conveyance systems

Aquestia is a world leader in providing optimal solutions for surge protection, water loss reduction and pressure management, by integrating uniquely developed products with innovatively designed software. Bringing together three strong brands - A.R.I., DOROT and OCV – we combine decades of experience, a wealth of knowledge and expertise, and a wide range of solutions and services. We are where liquid flows, serving customers in segments that include waterworks and wastewater systems, irrigation, fire protection, mining, ballast water, desalination, commercial plumbing, aviation fueling, oil & gas, and more.

**Aquestia – high-quality, reliable products and committed service - for your peace of mind.**